

Atlas Copco

DVS Series - Dry vane vacuum pumps

DVS 5-140



Atlas Copco's vacuum solutions continually build on a strong legacy of innovation and reliability. Our vacuum engineers and designers are always seeking to introduce newer technologies and revolutionize productivity for industrial markets across the globe. We keep in mind reduced carbon footprint and energy consumption, lower lifecycle costs, ease of maintenance and our customers productivity while designing and manufacturing our vacuum pumps.

DVS Series – Dry vane vacuum pumps

We introduce our new range of oil-free vacuum pumps – the DVS series. These are single-stage dry vane vacuum pumps which do not require oil to operate. This ensures a clean operation, free of emissions and no contamination to the process. These dry rotary vane vacuum pumps are designed to be robust, simple, clean, compact, and silent suited for rough industrial applications with high efficiency and competitive initial investment costs.

We offer dry vane vacuum pumps with nominal suction flow from 5 m³/h to 140 m³/h and ultimate vacuum level up to 120-150 mbar(a) depending on the model.

Working principle

The DVS series are positive displacement vacuum pumps. The design and technology maximize the level of vacuum created while minimizing energy consumption and wear and tear. Due to the rotation of the rotor the vanes inside slide. The vacuum is generated with minimum friction due to the high quality graphite alloy. These features together with the premium construction ensure a reliable pump and a long time between maintenance. Exhaust air goes through an air cooler to reduce the discharged air temperature.

The design of the DVS series combined with Atlas Copco's expertise ensures easy maintenance. Atlas Copco's highly resistant graphite vanes help achieve maximum durability with minimal wear and tear.

Included as standard on all models:

- inside inlet filter
- non-return valve
- exhaust silencer
- noise containing canopy (from DVS 16-140)
- energy efficient IE3 electric motor (from DVS 16-140)



Feature and benefits



Efficient:

- Direct drive
- Low noise level
- Small footprint
- Long time between service

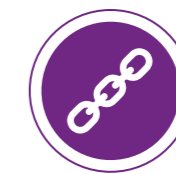

Robust Design:

- Reliable graphite vanes
- Construction without oil and oil filters
- Modular design
- Multiple operational features as standard



Clean:

- Dry and oil-free vacuum technology
- Air-cooled pump
- Oil-free operations with no emissions and contamination for your process

Applications

- Packaging
- Medical systems
- Pick and place
- CNC clamping
- Laboratory vacuum
- Holding, lifting, moving
- Pneumatic conveying
- Printing
- Woodworking

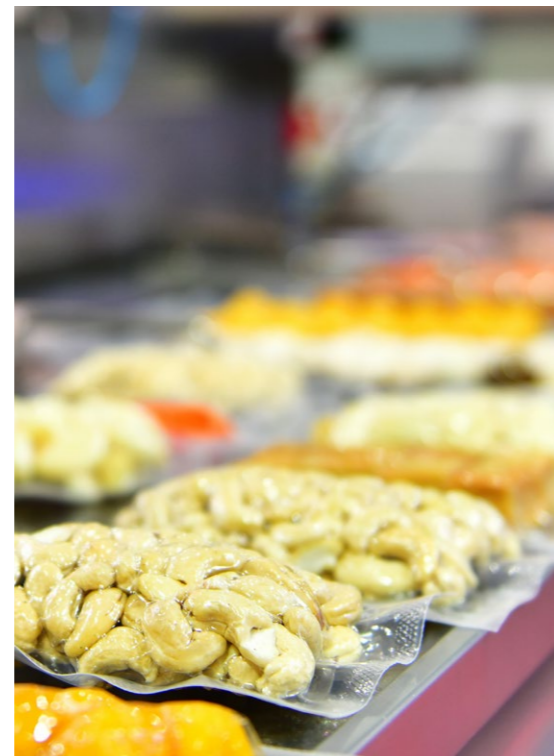

Technical specifications

		Unit	DVS 5	DVS 8	DVS 16	DVS 25	DVS 40	DVS 60	DVS 80	DVS 100	DVS 140
Nominal Flow	50Hz	m ³ /hr (cfm)	5 (3)	8 (4.7)	16 (9.4)	25 (14.7)	40 (23.5)	60 (35.3)	80 (47)	100 (59)	130 (76.5)
	60Hz		6 (3.5)	9 (5.3)	19 (11)	29 (17)	48 (28)	70 (41)	90 (53)	115 (67.7)	150 (88)
Ultimate vacuum level	50Hz	mbar(a) (Torr)	120 (90)	150 (112.5)	120 (90)	120 (90)	120 (90)	150 (112.5)	150 (112.5)	150 (112.5)	150 (112.5)
	60Hz		120 (90)	150 (112.5)	120 (90)	120 (90)	120 (90)	150 (112.5)	150 (112.5)	150 (112.5)	200 (150)
Maximum discharge pressure	50Hz	mbar(g) (Torr)	0.8 (0.6)	0.8 (0.6)	1.0 (0.75)	1.0 (0.75)	1.0 (0.75)	-	-	-	-
	60Hz		0.8 (0.6)	0.8 (0.6)	1.0 (0.75)	1.0 (0.75)	1.0 (0.75)	-	-	-	-
Nominal motor power	50Hz	kW (hp)	0.12 (0.16)	0.25 (0.33)	0.75 (1.0)		1.3 (1.7)	1.5 (2.0)	2.2 (2.9)	3.4 (4.5)	
	60Hz		0.15 (0.2)	0.3 (0.4)	0.9 (1.2)		1.5 (2.0)	1.8 (2.4)	3.0 (4.0)	4 (5.3)	
Motor speed	50Hz	rpm	2800			1400					
	60Hz		3300			1700					
Inlet connection	Thread	G	1/8"	3/8"	1/2"	3/4"	1"	1"	1"	1 1/2"	1 1/2"
Outlet connection	Thread	G	1/8"	1/2"	1/2"	1/2"	1"	1"	1"	1 1/2"	1 1/2"
Dimensions W x H x L	1ph version	mm	139 x 138 x 226	167 x 160 x 253	206 x 270 x 412	206 x 270 x 412	230 x 309 x 485	N/A x N/A x 692	N/A x N/A x 722	N/A x N/A x 820	N/A x N/A x 820
	3ph version		120 x 138 x 226	167 x 147 x 253	206 x 244 x 412	206 x 244 x 412	230 x 270 x 485	365 x 382 x 692	365 x 382 x 722	365 x 382 x 820	365 x 382 x 820
Weight	1ph version	kg (lbs)	5.4 (11.9)	8.5 (18.7)	31 (68.3)	31 (68.3)	42 (92.5)	N/A	N/A	N/A	N/A
	3ph version		5.4 (11.9)	8.5 (18.7)	33 (72.7)	33 (72.7)	45 (99.2)	66 (145.5)	71 (156.5)	87 (191.8)	95 (209.4)

Performance curves

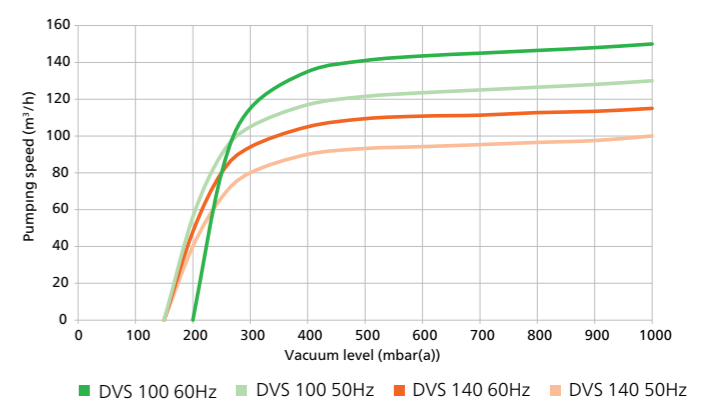
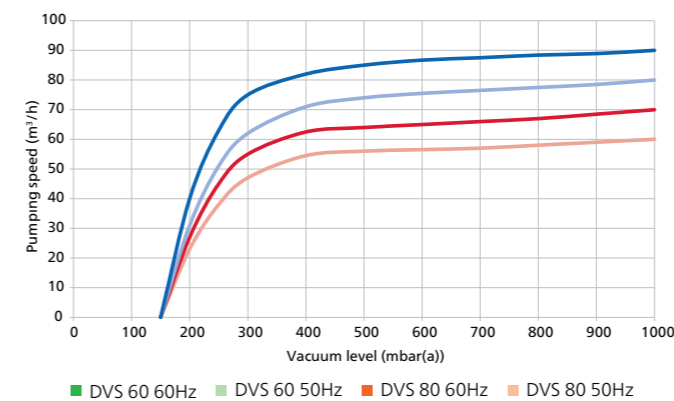
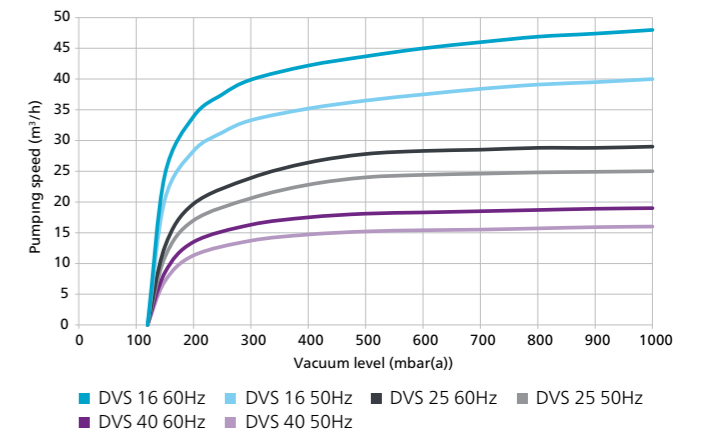
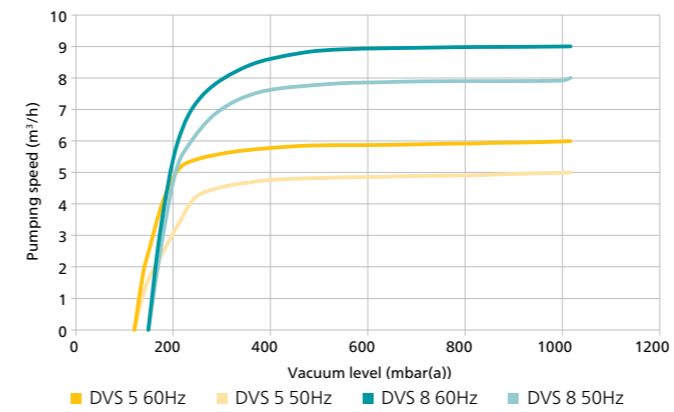

Technical drawings

DVS 5

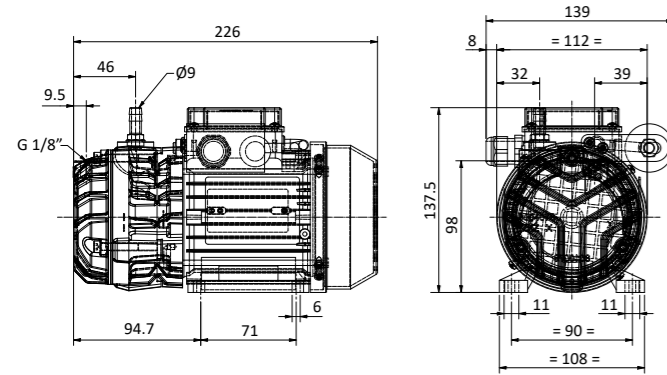

DVS 8

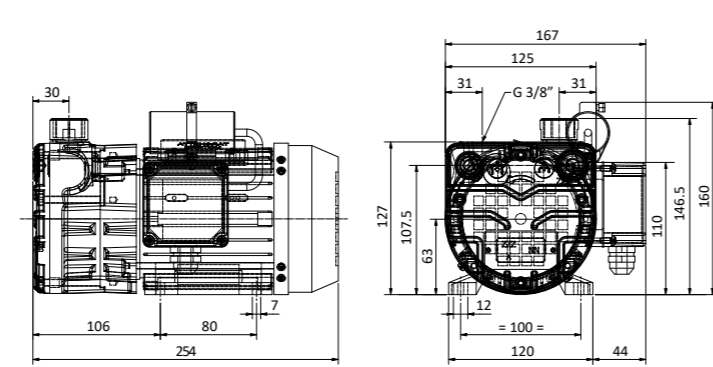

DVS 140

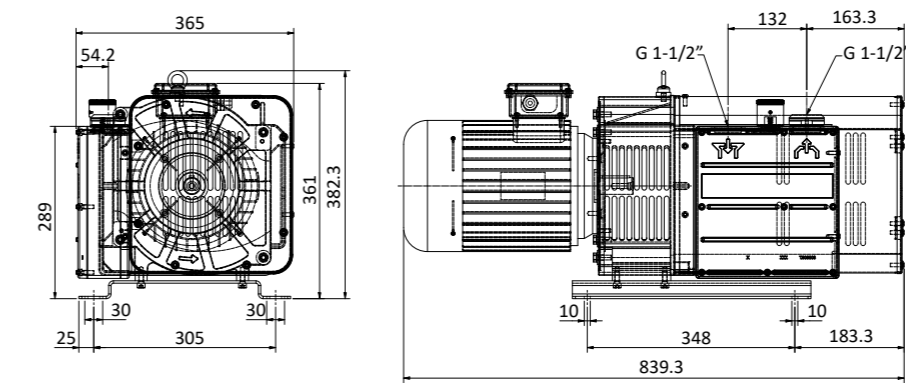

DVS 16

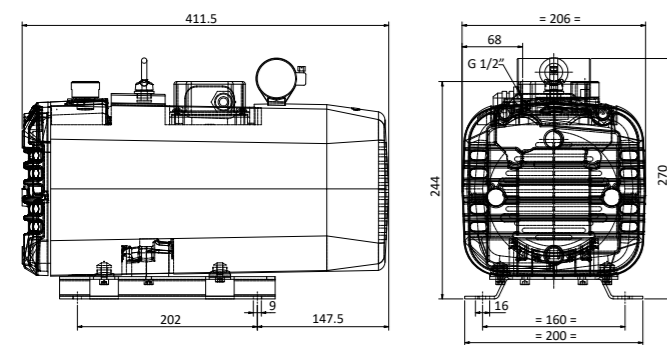

DVS 25

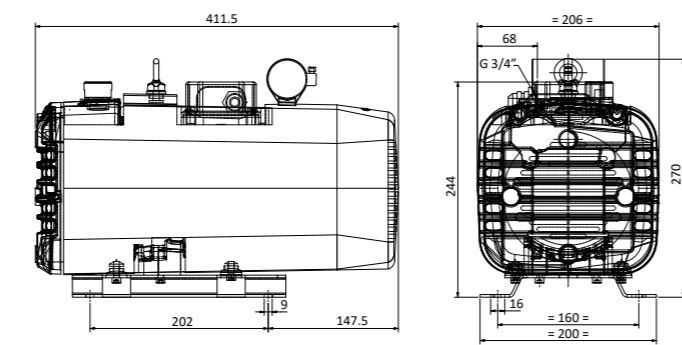

DVS 40

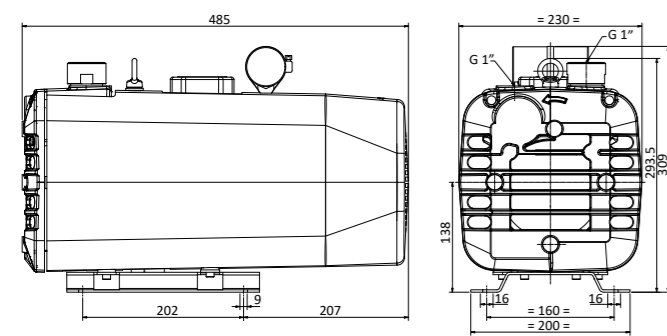

DVS 60

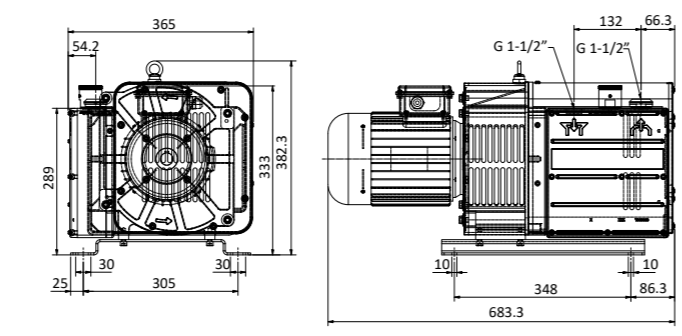

DVS 80

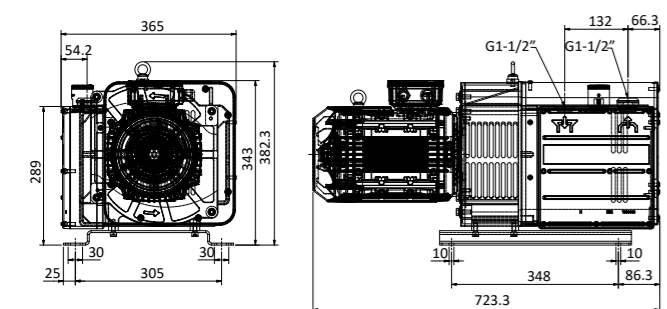

DVS 100

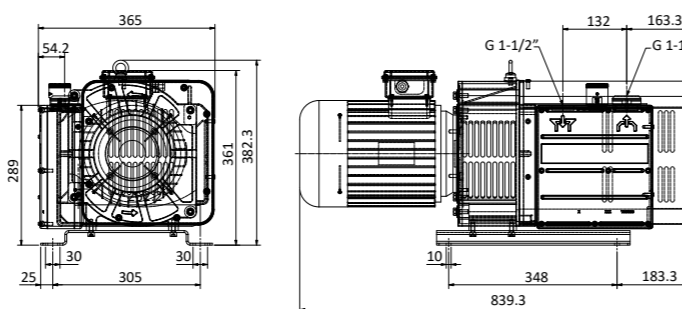

Accessories

	DVS 5	DVS 8	DVS 16	DVS 25	DVS 40	DVS 60	DVS 80	DVS 100	DVS 140
Shock mounts	✓	✓	✓	✓	✓	✓	✓	✓	✓
Inlet filter	✓	✓	✓	✓	✓	✓	✓	✓	✓
Vacuum regulating valve	✓	✓	✓	✓	✓	✓	✓	✓	✓
Vacuum gauge	✓	✓	✓	✓	✓	✓	✓	✓	✓
Pressure relief valve	✓	✓	✓	✓	✓	✗	✗	✗	✗
Inlet hose fitting	✗	✓	✓	✓	✓	✓	✓	✓	✓
Non-return valve	✗	✓	✓	✓	✓	✓	✓	✓	✓

Service support and maintenance



Complete service with our Preventive Care plan

We take over the maintenance planning and responsibility for servicing your vacuum pump on a regular basis. Our Preventive Care plan is tailored to your pump's needs. As your pump is serviced with the latest technology, high levels of energy efficiency are achieved. We will also optimize service events to reduce your total cost of ownership and increase your productivity. This allows you to focus fully on your production.



Maximize lifetime of your vacuum pumps

Our vacuum specialists are well-trained and experts in the field. They will help you to improve uptime and protect your processes. Regular maintenance conducted by one of our vacuum specialists reduces the risk of deterioration. Damaged or worn parts will be replaced with genuine Atlas Copco spare parts to protect your investment and increase the lifespan of your vacuum pumps.



Cost-effective approach

Regular scheduled maintenance can identify potential problems before they occur and plans can be structured around your individual production situation. Preventive Care enables cost management as you can plan your maintenance costs in advance. In this way, expenses associated with unplanned downtime are minimized.



Reliability meets non-stop productivity

We use genuine Atlas Copco spare parts and oil and our services are conducted by vacuum specialists according to manufacturer's recommendations. This enhances your vacuum pump performance, reducing the risk of downtime and enabling your production to run more smoothly.

